



Fabric Expansion Joints – Installation Guide

This leaflet is a joint publication of the European Sealing Association, the RAL and the Fluid Sealing Association.

Throughout the document, warnings are indicated in **red**, good practice is indicated in **green** and shipping straps are indicated in **yellow**.

This document has been presented by:

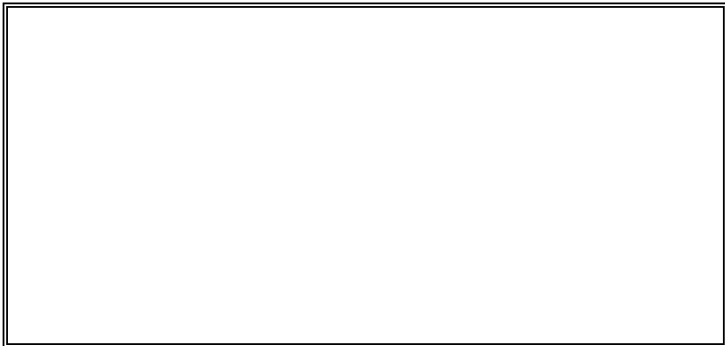

- ensure the correct orientation of the expansion joint with regard to duct flow direction if the expansion joint is marked accordingly match flow arrow direction on the expansion joint with duct
- where fitted, internal flow sleeves must be in good order and in the correct orientation
- the necessary amount of bolts, nuts and washers are available
- any clamp bars flanges in sections (of max length 2m) are dimensioned so that the distance between the sections is max 2mm after installation and tightening. Improvement to the sealing between the bars can be achieved by using suitable shims. Avoid pinching the expansion joint fabric

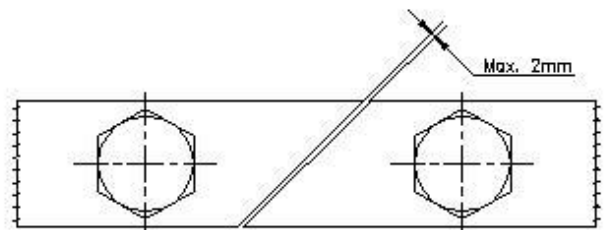
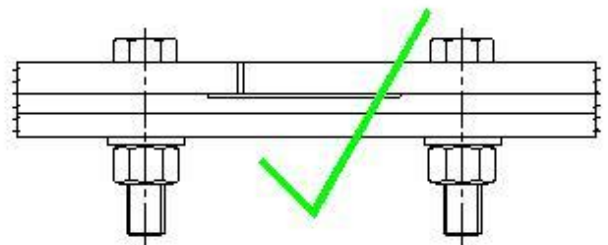
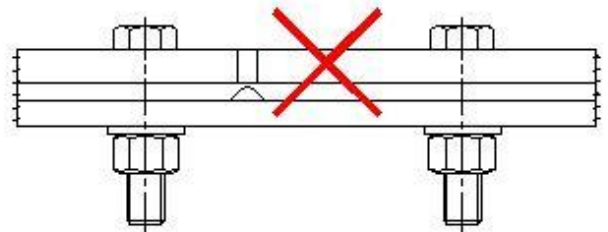

1. Pre-installation checks

Please check the following items before installing the expansion joint:

- confirm expansion joint design
- duct flanges are in a good condition and are fully and continuously welded and free of sharp edges, burrs etc.
- dimensions and holes on duct flanges and installation measurements are correct
- dimensions on duct flanges are correct and according to specification (especially important are the breach opening, installed length and the bolting detail)
- duct flanges are lined up correctly (ensure that lateral displacement and angular movement do not exceed agreed specifications)
- whatever design method is used, ensure that the fabric does not foul the adjacent metalwork under operating conditions
- all metal edges in contact with flexible materials are radiused

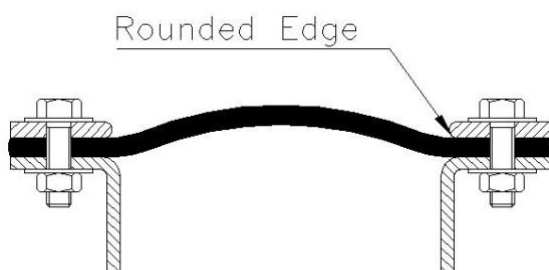

For flanged expansion joints, please check in addition:

- bolt heads do not damage the outer layers of the expansion joint during operation
- in confined spaces or when large movements are likely, countersunk or carriage head bolts may be required

Please contact the supplier in any case where packing is damaged during transport or storage.

If one or more of the above items are found to be wrong when compared with specifications, please contact the manufacturer immediately.

Never install damaged components!

2. Handling for installation

It is assumed that the expansion joint and its components are now at the point of installation and hence will be stored for a short period only just prior to installation (for details of longer term storage, please refer to **ESA Expansion Joints - Engineering Guide**, ESA Publication No. 011/01, page 32, or RAL document **TI-008**). For short term storage, the following conditions should be observed:

- during short term storage outside, the flexible element (and bolster, if included) must be covered with an appropriate weather-proof cover and should be protected against humidity and dampness from the ground
- an ideal temperature to install components to give optimum handling is around 20°C (68°F). Progressively below this temperature, materials become stiffer, making handling difficult. Under these conditions, it is recommended that the expansion joint should be stored inside a warmer environment immediately prior to installation

For any movement required at the point of installation:

- unpacked expansion joints must be placed on a secure base (e.g. pallet) and must be protected temporarily during any site transportation
- the attachment points for the lifting equipment must be on the base (pallet)
- where appropriate, always use several persons for carrying
- do not drag expansion joints or bolsters along the ground or across edges

To ensure correct installation, and thereby preserve the reliability and working life of the expansion joint, the following instructions must be observed:

- ensure components are installed in the correct sequence
- erection of suitable scaffolding around the workplace is essential for efficient installation
- large and heavy expansion joints must be supported during installation and should be installed with appropriate lifting equipment

- fabric expansion joints must **not** be lifted by attaching the lifting device directly to the fabric. The fabric expansion joint should rest on a supporting base, to which lifting tackles can be attached
- the holes in the expansion joint flange should **never** be used to lift the expansion joint
- at all times, protect the expansion joint from welding sparks and sharp objects, where appropriate
- **never** walk on, or place scaffolding on, the expansion joint
- fabric expansion joints which have been pre-assembled by the manufacturer must be lifted by the lifting points and **not** by their shipping straps (unless the manufacturer has combined the two specifically)

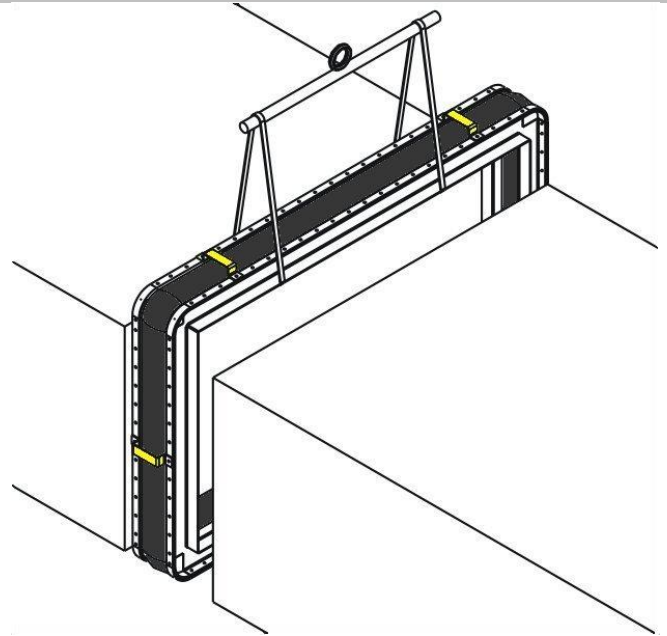

- any protective cover and / or shipping straps must **not** be removed until installation is completed, but **must** be removed immediately prior to plant start up

3. Installation of bolster

If no bolster is included in the design, please ignore this section and go on to section 4.

A bolster can be installed in several different ways, depending upon the individual design and construction, and may have specific additional instructions supplied by the manufacturer. Specific note should be taken of:

- it is essential that the bolster must be kept dry during installation and until the flexible element provides a weather-proof cover (take care also that water does not come down inside the ducting)
- if the bolster has integral flanges, then in principle it should be wrapped around the ducting and secured temporarily with suitable clamps which support the unit adequately
- joining or splicing of the bolster should be carried out according to manufacturers instructions (please see Section 4, Joining or splicing)
- the outer flexible element should be wrapped around the ducting on top of the bolster and both items secured together
- in the case of loose bolsters, these should be wrapped around the ducting (as mentioned above). In some instances, the use of clamps is not practicable and in these instances a suitable thread can be used to tie across the breach opening to support the bolster. This thread may be left *in situ* when the expansion joint is fitted (note, the thread may break when the expansion joint is moved, but this is not a problem)
- other fixation methods are available, for example pins and washers fitted to side wall for fixing u-shaped bolsters. These will be specified by the manufacturer

4. Joining or splicing

Joining or splicing techniques, for both the bolster and the flexible element, may vary dependent on the types of material and application. The integrity of the expansion joint may be seriously compromised if the joining or splicing is not carried out precisely according to the manufacturer's specification.

Therefore, it is critical that the manufacturer's joining or splicing instructions are followed precisely.

To facilitate the ease of joining, the position of the final splice is recommended at the top horizontal run of the vertical joint and, ideally, mid-way between the corners. In expansion joints which incorporate a pre-set in the ducting, position the splice in the sides where the material will not suffer the effects of the shear force.

To prevent thickness build-up in the clamping area, the position of the splices of the bolster and that of the flexible element should be staggered.

5. Installation of flexible element

Having installed the bolster, the flexible element may now be wrapped around the duct flanges ensuring that the final splice is as specified above (see Section 4.).

The flexible element should be secured or supported temporarily using suitable clamping devices at suitable positions along the element to distribute weight. Do not support at ends only.

If the flexible elements are supplied with **ready-made** holes from the factory, clamp bar and bolts can be fitted loosely immediately. In these cases, do **not** drill extra holes or modify the existing holes as this may result in leakage in the flange area. **If the holes do not align, contact your supplier for advice.**

For expansion joints supplied **without** holes, holes can be made using the following method:

- (i) place the expansion joint around the duct flanges
- (ii) position the backing flanges correctly on the expansion joint flange and secure with suitable clamps
- (iii) drill through the expansion joint material using the backing flange as a guide

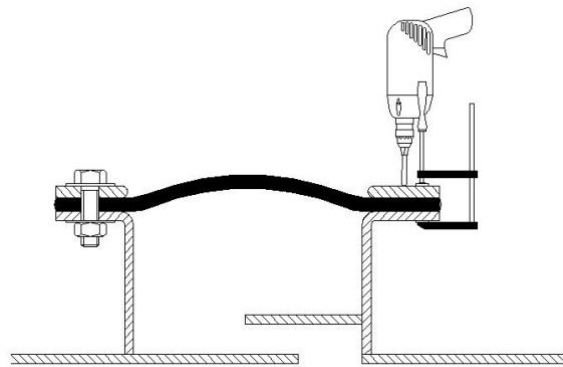

NB It is very important that the clamps (on both sides of the hole) hold the material securely otherwise the fabric and the insulating materials may rotate with the drill, resulting in tearing.

If expansion joints need joining or splicing, please see Section 4, Joining or splicing.

The torque required for tightening the bolt varies dependent upon the type of expansion joint, bolt dimensions, lubrication, bolt pitch etc. (see Section 8. **Bolting**).

All clamp bars, including nuts and bolts, must be in place and hand-tight before final tightening. It will then be possible to adjust the expansion joint material and the clamp bars to ensure best fit.

If there is any likelihood of damage by, for example, welding sparks, sharp objects etc., then a protective cover should be fitted, but ensure this is removed just prior to initial start-up (warning: failure to remove the cover before start-up may damage the expansion joint irreparably). **Never** walk on, or place scaffolding on, the expansion joint.

6. Installation of pre-assembled units

An expansion joint unit often consists of flexible element, bolster and steel components, pre-assembled at the factory before delivery. These are installed into the ducting in much the same way as a normal expansion joint section.

It is important to check that the dimensions of the ducting and the pre-assembled unit conform to the specification.

The pre-assembled unit may be pre-compressed to 20mm less than the ducting gap and secured with shipping straps to ensure ease of fitting in between duct ends. These pre-assembled units must be lifted by the lifting points and **not** by their shipping straps (unless the manufacturer has specifically combined the two).

The protective cover and shipping straps must **not** be removed until one end of the expansion joint has been secured to one flange of the ducting, having had any sealing (gasket) tape fitted first. Once fully tightened, the remaining (free) expansion joint flange requires suitable support, such that shipping straps can be removed and the pre-assembled unit extended to fill the gap, ensuring that any sealing (gasket) tape has been fitted between the flanges first. It is important that the free end must be supported adequately before removing the shipping straps, in order to prevent damage to the expansion joint by compression or bending. In some cases the shipping straps are adjustable, in which case the pre-assembled unit may be extended by jacking out the flange.

Replace any protective cover. This should be removed only just prior to first start-up (warning: failure to remove the cover before start-up may damage the expansion joint irreparably).

7. Gaskets

In most cases, the flexible element itself acts as the sealing material and no additional gaskets are required. However, any metal-to-metal contact faces will require a gasket. For example, gaskets will be required with:

- pre-assembled expansion joint units
- loose-fitted internal flow sleeves

Also, any single layer flexible elements composed of fluoro-plastics require expanded PTFE tape as the sealing material.

In every case, the gasketing material must be appropriate for the application.

For applications requiring Nekal tightness, special materials may be provided and extra care should be taken during assembly.

The correct load must be applied to the gasket (see Section 8. **Bolting**).

Always use the thinnest gasket which the flange arrangement will allow, but thick enough to compensate for unevenness of the flange surfaces, etc.

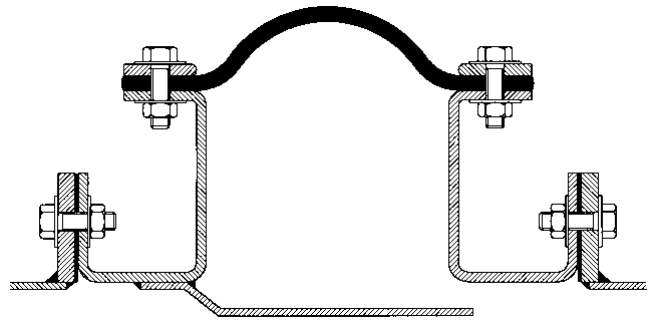

8. Bolting

The required bolt loading will vary, dependent upon the type of expansion joint, bolt dimensions, bolt lubrication, bolt distance etc.

All clamp bars, including their bolts and nuts, must be in place and hand-tight before tightening further.

Recommended flange loading for fabric expansion joints is 3 MPa (435 psi) unless otherwise agreed with the manufacturer. Bolt torque, converted from this recommended flange loading, can be obtained from the manufacturer, which assumes all load-bearing threads have appropriate lubrication. Bolt threads must be lubricated with a suitable lubricant in order to achieve the correct loading.

The bolt loading guide (below) is valid for MoS₂-lubricated bolting, with the recommended loading in **green**.

These values are to be used as a guide only. **Load the bolting as advised by the expansion joint manufacturer.**

Bolt loading guide:

Imperial (inches)								
width of clamp bar	2		2 ^{3/8}		2 ^{3/4}		3 ^{1/8}	
thickness clamp bar	5/16	1/2	3/8	1/2	3/8	1/2	1/2	
bolt spacing	4		4		4 ^{3/4}		4 ^{3/4}	
bolts	1/2	5/8	5/8	3/4	5/8	3/4	5/8	3/4
recommended tightening torque in ft. lbs:								
loading for fabric expansion joint	44	59	74	88	85	103	96	118
loading for elastomeric expansion joint	37	44	55	66	66	81	74	92
Metric (mm)								
width of clamp bar	50		60		70		80	
thickness of clamp bar	8	10	10	12	10	12	12	
bolt spacing	100		100		120		120	
bolts	M12	M16	M16	M20	M16	M20	M16	M20
recommended tightening torque in Nm:								
loading for fabric expansion joint	60	80	100	120	115	140	130	160
loading for elastomeric expansion joint	50	65	75	90	90	110	100	125

9. External duct insulation

These components are usually the responsibility of others. However, it is important that the termination point of the external insulation conforms exactly to the agreed design and specification. Any variations to the agreed design could affect the life and performance of the expansion joint severely.

As a general rule, expansion joints must **not** be insulated on the outside (although there are exceptions to this with certain material types and designs). External insulation should **not** be used unless specified by the manufacturer.

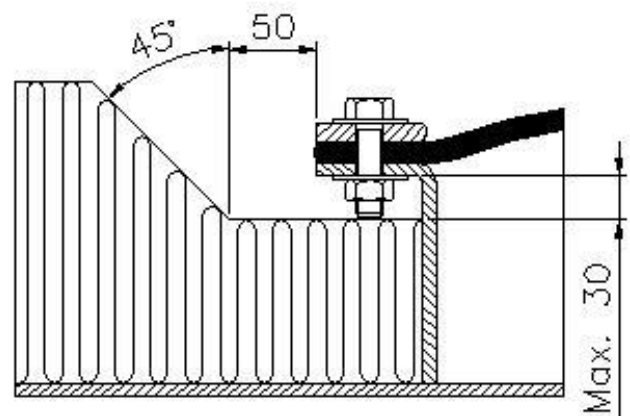
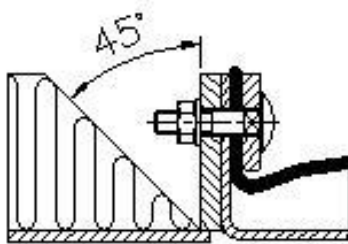
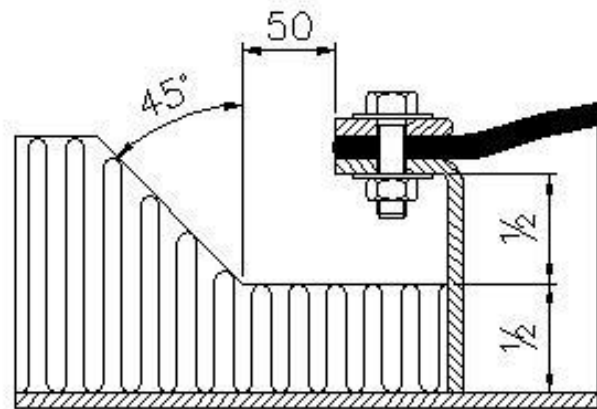

10. Prior to start-up check

Ensure all bolts and flanges are tightened correctly.

Check that misalignment / offsets do not exceed installation tolerances...contact manufacturer if needs be.

Make sure there are no surface defects or damage.

Remove any surface debris.

Ensure that all shipping straps and protection covers are removed before the plant is started.

Ensure there are no obstructions around the expansion joint which could prevent air flow and cause overheating.

Check the termination of any ducting insulation, local to the expansion joint, is to specification.

Unless otherwise agreed, the above instructions must be followed very closely.

11. Post start-up activities

When the expansion joint is heated (such as during plant start-up), the expansion joint components will settle. Therefore, expansion joint bolts should be re-tightened as soon as possible after start up and not later than at the first shut down. Tighten only to the manufacturer's recommended bolt torque.

Verify actual movements to ensure compliance with specification. Note hot/cold dimensions together with other operational parameters for record purposes, in case of trouble-shooting later.

Especially in the early days of operation, monitor the outer cover for any discolouration or damage, indicative of excessive heat or movement. Also, observe adjacent surfaces for any staining, which may indicate gas leaks.

When the system is operating, check that the bolt heads do not touch the outer layers of the expansion joint.

12. Operation and regular maintenance

Expansion joints belong to a group of products, which are classed as wearing parts; that is, parts which need to be replaced at regular intervals. Costly shutdowns and emergency situations can often be avoided by replacing wearing parts early enough.

Although expansion joints do not require actual maintenance, they should be checked regularly for signs of damage or degradation (please refer to sections 10 and 11 above).

The first sign of damage or degradation to a fabric expansion joint may be visible on the outer cover; the coating may start to discolour or peel, depending on the type of material/damage. Even before these signs are outwardly visible, thermal imaging can often identify hot spots and potential problem areas.

However, please note that discolouration may also result from chemical or acidic attack, which will not be visible with thermal imaging.

Regular inspection should include checks for:

- adequate ventilation around the expansion joint
- loose bolts
- signs of damage or leakage, such as local staining, cracks in the expansion joint metal frame and adjacent metalwork, discolouration or peeling
- condensate (may be observed as excessive residue)
- signs of damage on the external insulation

Take any remedial action required.

Where feasible, an internal check of the expansion joint is recommended during plant shutdown. The expansion joint manufacturer will be pleased to advise on internal and external inspection.

Consider replacement in a planned maintenance programme, to prevent the consequences of unforeseen failure.

13. Disposal of used components

Disposal of used components is the responsibility of the user.

Disposal must comply with all local and national regulations.

Do not incinerate fluoro-plastic or fluoro-elastomeric components because they may release toxic gases.

Take care as the expansion joint materials may have been contaminated during use, after contact with noxious substances from the plant. Take suitable precautions if this is likely. Historically, some of the expansion joint components, insulation or gaskets may have been made with materials now deemed to be hazardous. Before disassembly, users should be aware of the nature of all of the materials involved and take appropriate care.

Notes

The document focuses on the installation of the expansion joint and assumes that the joint and its components are now at the point of final installation. For an explanation of terms used in this document, including details of packaging, transport, storage, health and safety, please refer to the **ESA Expansion Joints - Engineering Guide** (ESA Publication No. 011/01, published 2001 January).

This publication is the copyright © 2003 of the European Sealing Association, the RAL and the Fluid Sealing Association. All rights reserved.

No part of this publication may be reproduced in any form without prior written permission of the ESA, RAL or FSA.

This publication is intended to provide information for guidance only. The European Sealing Association, the RAL and the Fluid Sealing Association have made diligent efforts to ensure that recommendations are technically sound, but do not warrant, either expressly or by implication, the accuracy or completeness of the information, nor do the Associations assume any liability resulting from the reliance upon any detail contained herein. Readers must ensure products and procedures are suitable for their specific application by reference to the manufacturer. Also, the document does not attempt to address compliance requirements of regulations specific to a particular industrial facility. Readers should consult appropriate local, regional, state, national or federal authorities for precise compliance issues.

The **European Sealing Association** (ESA) is a pan-European organisation, established in 1992 and representing over 85% of the fluid sealing market in Europe. Member Companies are involved in the manufacture, supply and use of sealing materials, crucial components in the safe containment of fluids during processing and use.

European Sealing Association

Bowerham House

The Grove

Lancaster LA1 3AL

United Kingdom

☎ : +44 1524 844 222

Fax: +44 1524 844 222

www.europeansealing.com

The **RAL Quality Assurance Association** was founded in Germany in 1990 as a "RAL Gütegemeinschaft", meaning that the quality mark is acknowledged by both governmental and non-governmental bodies involved with non-metallic expansion joints. The aims are to create and upgrade a high quality standard guaranteed for each product delivered by a Member Company. The quality mark is based on a third party control system, supported by a special quality management system certified according to ISO 9000, to ensure the quality principles of the quality mark in each stage of manufacturing.

**Gütegemeinschaft Weichstoff Kompensatoren e.V.
(RAL)**

Heinestraße 169,

D - 70597 Stuttgart-Sonnenberg,

Deutschland

☎ : +49 711 976 580

Fax: +49 711 976 5830

www.qafej.org

The **Fluid Sealing Association** (FSA) is an international trade association, founded in 1933. Members are involved in the production and marketing of virtually every kind of fluid sealing device available today. FSA membership includes a number of companies in Europe and Central and South America, but is most heavily concentrated in North America. FSA Members account for almost 90% of the manufacturing capacity for fluid sealing devices in the NASFTA market.

Fluid Sealing Association

994 Old Eagle School Road

Suite 1019

Wayne, PA 19087 – 1802

United States of America

☎ : 610 971 4850

Fax : 610 971 4859

www.fluidsealing.com